

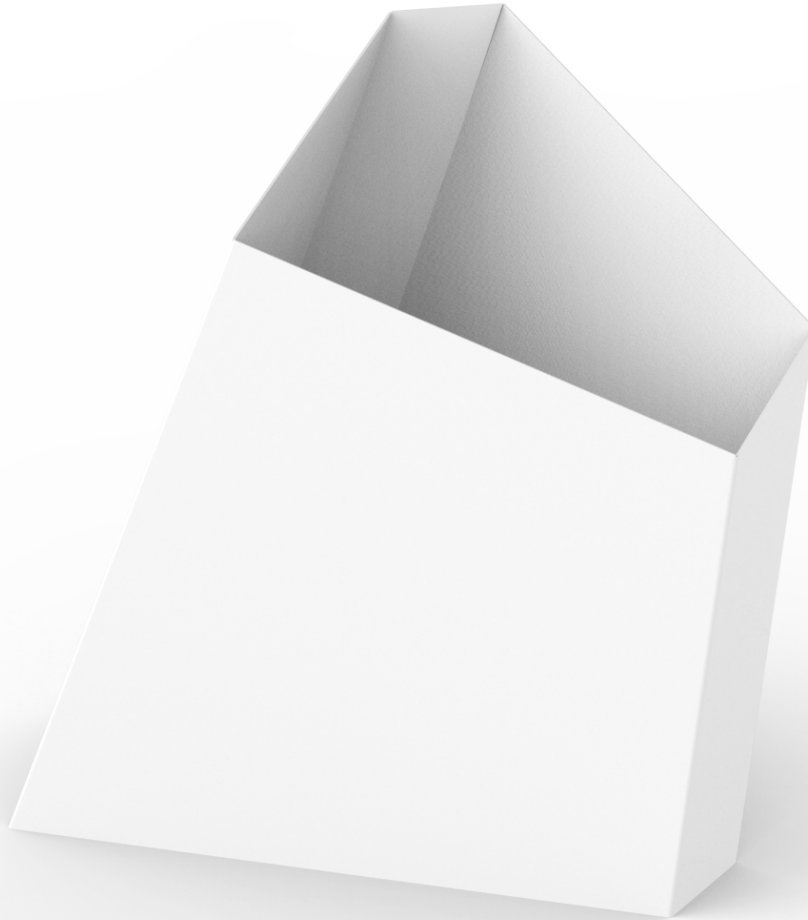

P L A N T E R W O R X  
C O N T R A C T



**ELEMENT E-19 PLANTER**

19"H x 20"W x 11"D

VOLUME: 6 US GALLONS | 0.8 CUBIC FEET

MANUFACTURED FROM:

.125" ASTM A240 STAINLESS STEEL | NDSF FINISH ONLY | 20 lbs

T-304 (T-316L BY REQUEST),

.125" CORTEN STEEL ASTM A588 | 20 lbs

OR .125" ALUMINUM ASTM B-209, 5052 ALLOY | 7 lbs

WITH A POLYESTER BASED ARCHITECTURAL/MARINE GRADE POWDER COAT FINISH

AVAILABLE IN STANDARD FINISHES OR IN ANY RAL COLOR

DRAINAGE HOLES INCLUDED | MAY BE MANUFACTURED IN MIRRORED PAIRS

P L A N T E R W O R X 9 8 7 E S S E X S T B R O O K L Y N N Y 1 1 2 0 8

T 7 1 8 . 9 6 3 . 0 5 6 4 F 7 1 8 . 9 6 3 . 0 5 6 5

P L A N T E R W O R X . C O M



# P L A N T E R W O R X

## C O N T R A C T

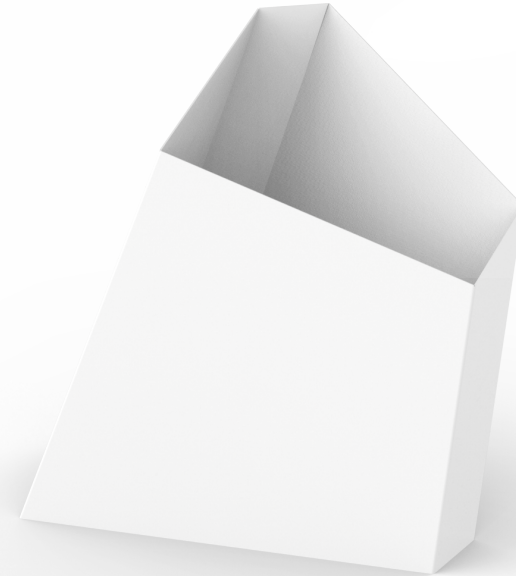
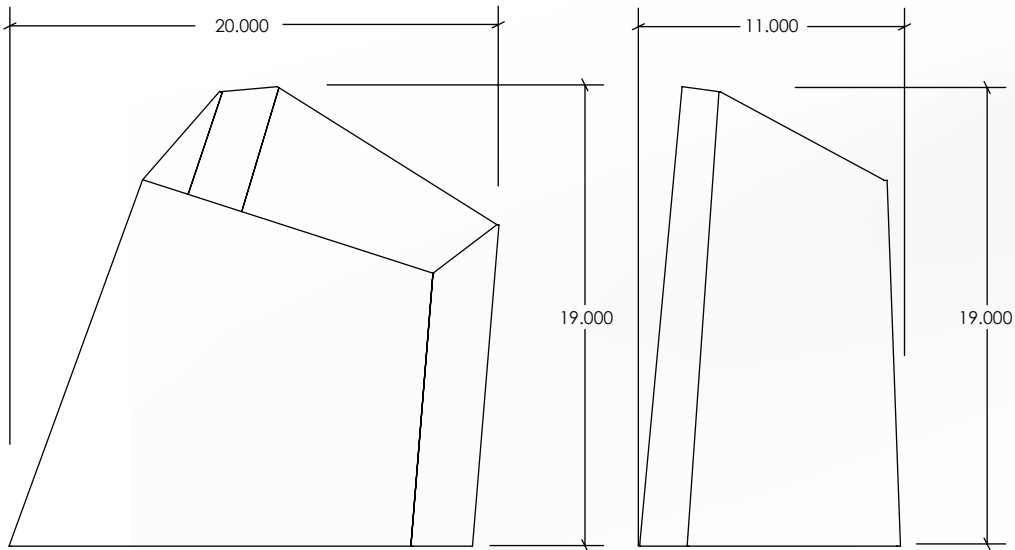
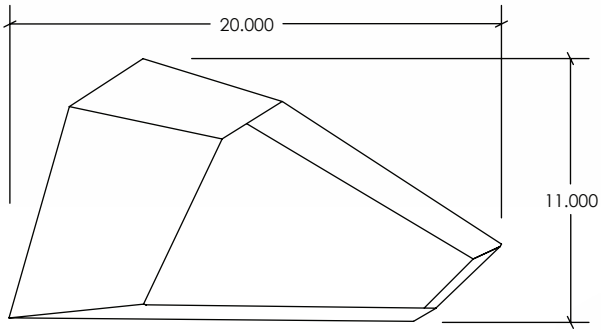

### ELEMENT E-19 PLANTER

19"H x 20"W x 11"D

VOLUME: 6 US GALLONS | 0.8 CUBIC FEET

MANUFACTURED FROM:

.125" ASTM A240 STAINLESS STEEL | NDSF FINISH ONLY | 20 lbs

T-304 (T-316L BY REQUEST),

.125" CORTEN STEEL ASTM A588 | 20 lbs

OR .125" ALUMINUM ASTM B-209, 5052 ALLOY | 7 lbs

WITH A POLYESTER BASED ARCHITECTURAL/MARINE GRADE POWDER COAT FINISH

AVAILABLE IN STANDARD FINISHES OR IN ANY RAL COLOR

DRAINAGE HOLES INCLUDED | MAY BE MANUFACTURED IN MIRRORED PAIRS

P L A N T E R W O R X 9 8 7 E S S E X S T B R O O K L Y N N Y 1 1 2 0 8

T 7 1 8 . 9 6 3 . 0 5 6 4 F 7 1 8 . 9 6 3 . 0 5 6 5

P L A N T E R W O R X . C O M